

# Remeha P 200 Technical information

Pressurized boiler

Heat output:  
59 - 256 kW

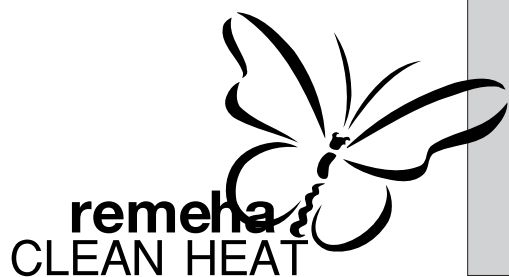

## CONTENTS

<b>Preface</b>	3	<b>8. Instrument panels</b>	10
<b>1. Description of the unit</b>	4	8.1 Equipment contents	10
1.1 General	4	8.2 Instrument panel On/Off	10
1.2 Burners	4	8.2.1 Lay out instrument panel On/Off	10
<b>2. Construction data</b>	4	8.2.2 Wiring diagram instrument panel On/Off	11
2.1 General	4	8.3 Instrument panel High/Low	12
2.2 Sections	4	8.3.1 Lay out instrument panel High/Low with hour run meters	12
2.3 Casing	4	8.3.2 Wiring diagram instrument panel High/Low	13
<b>3. Technical data and dimensions</b>	5	<b>9. Commissioning</b>	14
<b>4. Output data</b>	6	9.1 Pressurized boiler with gas burner	14
4.1 Boiler efficiency	6	9.1.1 Commissioning procedure	14
4.2 Combustion efficiency	6	9.1.2 Putting out of operation	14
<b>5. Application data</b>	6	9.2 Pressurized boiler with oil burner	14
5.1 L.P.H.W. version	6	9.2.1 Commissioning procedure	14
5.1.1 Water temperature	6	9.2.2 Putting out of operation	14
5.1.2 Water pressure	6	<b>10. Fault finding</b>	15
5.1.3 Flow rate	6	10.1 High Limit thermostat lockout	15
5.1.4 Water treatment	6	<b>11. Maintenance recommendations</b>	15
5.2 Economisers	6	11.1 General	15
5.3 Flue gas discharge	6	11.2 Maintenance instructions	15
5.4 Noise production	6		
<b>6. Installation requirements</b>	7		
6.1 Installation recommendations in the boiler house	7		
<b>7. Assembly guidelines and installation requirements</b>	8		
7.1 General	8		
7.2 Water connections	8		
7.3 Delivery in individual parts	8		
7.3.1 General	8		
7.3.2 Boiler assembly	8		
7.4 Delivery assembled (4 to 7 sections only)	8		

## PREFACE

These technical instructions contain useful and important information for the proper operation and maintenance of the central heating boiler, model Remeha P 200.

Further it contains important directions to prevent accidents and serious damage before putting it into service and during operation of the boiler, to allow as far as possible safe trouble free operation.

Read these instructions carefully before putting the boiler into service, familiarize yourself with its operation and control and strictly observe the directions given.

If you have any questions, or if you want more information about specific items relating to this boiler, please do not hesitate to contact us.

The data published in these technical instructions is based on the most recent information and is given subject to later revisions.

We reserve the right to modify the construction and/or design of our products at any moment, without obligation to update earlier supplies accordingly.

## 1. DESCRIPTION OF THE UNIT

### 1.1 General

High efficiency pressurized boiler, suitable for use with natural gas and light oil, by means of a pressure jet burner. Also available with a condensing unit (ECO) (for natural gas only).

Up to 141 kW the Remeha P 200 can be delivered assembled (except for casing and instrument panel). The boiler meets the requirements of the CE regulations at the following directives:

- Gas appliance directive no. 90/396/EEC
- Electrical low voltage directive no. 73/23/EEC
- E.M.C. directive no. 89/336/EEC
- Efficiency directive no. 92/42/EEC.

Classification type for evacuation of the combustion products: B23.

### 1.2 Burners

In principle all pressure jet burners are suitable, subject to prior adjustment to the boiler capacity and boiler construction. The individual boiler satisfies inspection requirement for central heating boilers.

## 2. CONSTRUCTION DATA

### 2.1 General

The boiler block consists of cast iron sections which are assembled by means of tapered nipples. The boiler is a three pass design. The boiler block is insulated with a 80 mm thick layer of glass wool.

### 2.2 Sections

The sections are made of pearlitic cast iron.

Weights and measures of the sections:

- Front section: 59 kg H x W = 630 x 540 mm
- Intermediate section: 58 kg H x W = 630 x 540 mm
- Rear section: 61 kg H x W = 630 x 540 mm

### 2.3 Casing

Steel casing, finished with a high-quality insulation. The front door is suitable for left or right opening as required.

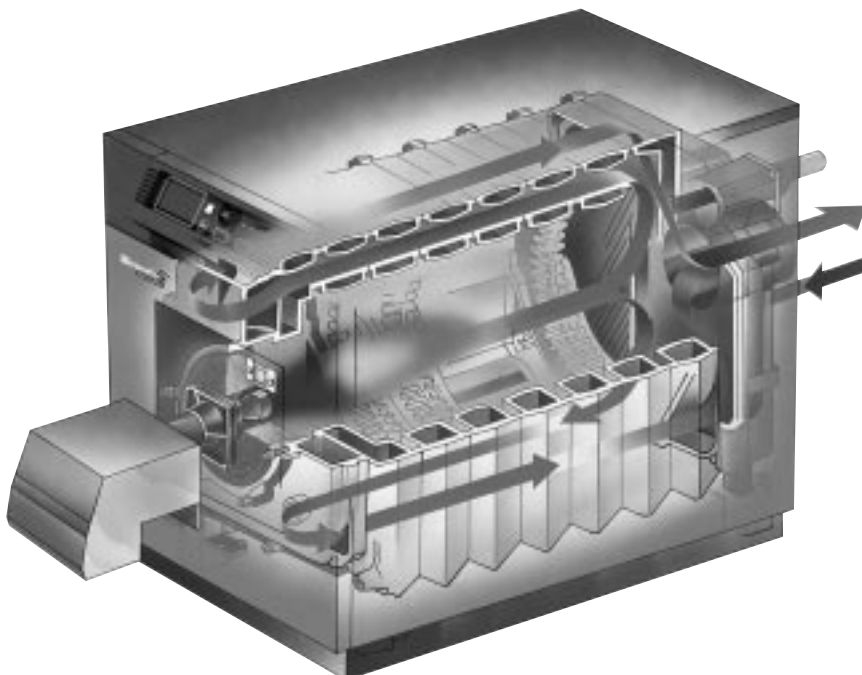

Fig. 01 Remeha P 200

### 3. TECHNICAL DATA AND DIMENSIONS

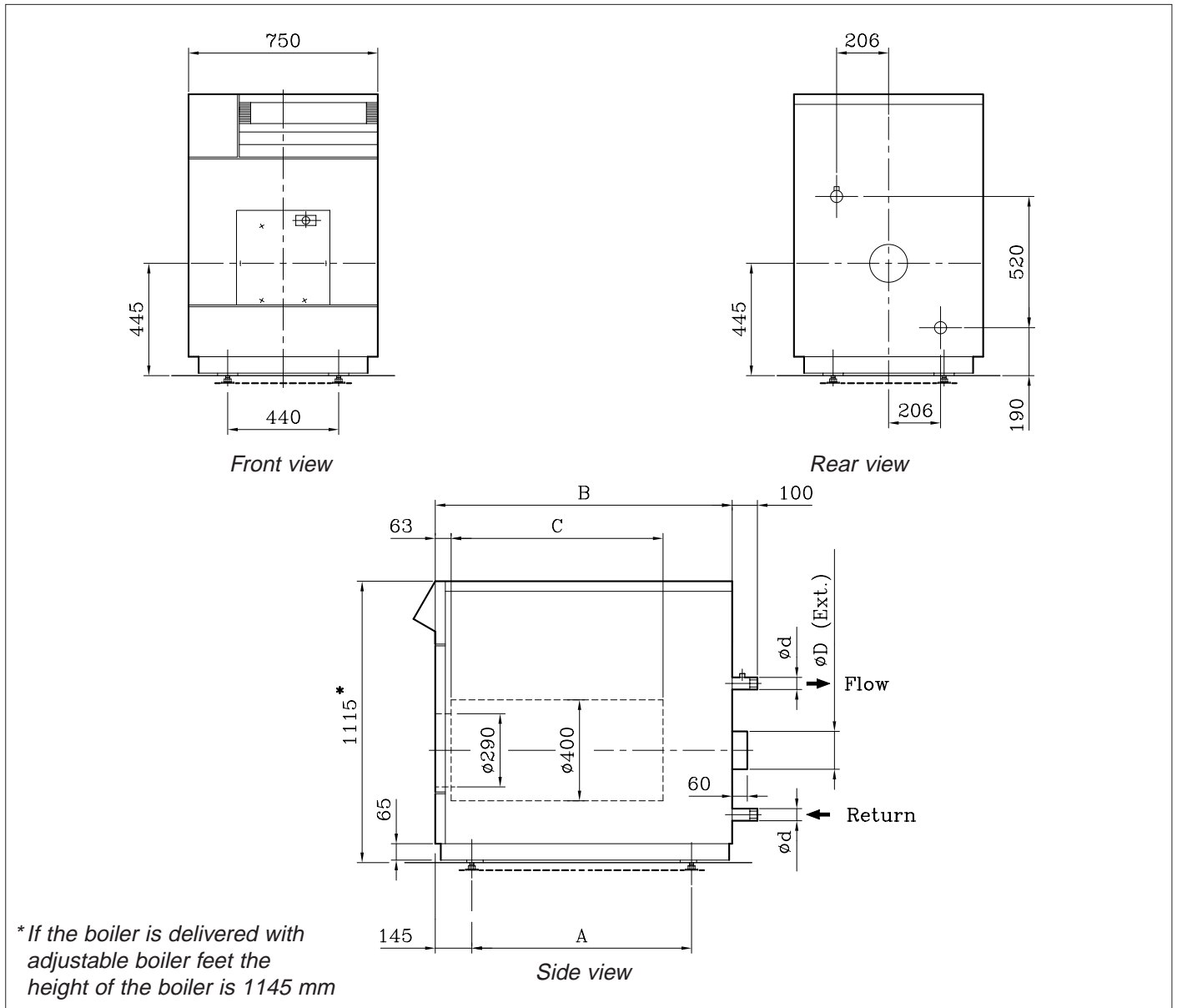

Fig. 02 Dimensions

No. of sections	Output kW	Nominal input		Combustion chamber resistance <sup>1)</sup> mbar	Combustion gas side content m <sup>3</sup>	Water resistance		Water content litres	Weight (dry) approx. kg	Flue gas mass rate kg/h	Sizes				
		Hi kW	Hs kW			$\Delta t = 20^{\circ}\text{C}$	$\Delta t = 10^{\circ}\text{C}$				A	B	C	$\phi D$	$\phi d$
											mm	mm	mm	mm	mm
4	34 - 59	66	73	0.1	0.08	2	9	24	365	103	492	791	450	150	1 1/2"
5	40 - 93	103	114	0.3	0.11	5	22	29	425	161	618	917	575	150	1 1/2"
6	46 - 117	129	143	0.6	0.13	8	34	34	485	201	745	1044	700	150	1 1/2"
7	52 - 141	155	172	1.0	0.16	12	48	39	545	242	871	1170	825	150	1 1/2"
8	58 - 165	181	201	1.2	0.18	17	67	44	605	282	998	1297	950	200	2"
9	65 - 184	202	224	1.6	0.21	21	84	49	665	315	1124	1423	1075	200	2"
10	71 - 206	225	250	1.4	0.23	26	103	54	725	351	1250	1549	1200	200	2"
11	77 - 229	250	278	1.8	0.26	32	127	59	775	390	1377	1676	1325	200	2"
12	83 - 256	278	309	2.1	0.28	39	158	64	835	434	1503	1802	1450	200	2"

<sup>1)</sup> Determined with 20 % excess air.

## 4. OUTPUT DATA

### 4.1 Boiler efficiency

Up to 91.7 % at Hi (82.6 % at Hs) at full load and up to 93.2 % at Hi (84.0 % at Hs), at part load.  
Average water temperature 70°C (80/60°C).

### 4.2 Combustion efficiency

Up to 93.0 % at Hi (83.8 % at Hs) at full load and up to 95.5 % at Hi (86.0 % at Hs) at part load.

## 5. APPLICATION DATA

### 5.1 L.P.H.W. version

#### 5.1.1 Water temperature

Maximum water temperature is 110°C.  
The minimum acceptable return water temperature is, for gas fired boilers 45°C and for oil fired boilers 40°C, at a flow rate corresponding to a  $\Delta t$  of 20°C at nominal heat output.

#### 5.1.2 Water pressure

Maximum pressure 6 bar.  
The boiler is suitable for open and sealed systems up to a maximum pressure of 6 bar and a minimum pressure of 0.8 bar. The boiler is suitable for installation in basement or rooftop boiler houses.

#### 5.1.3 Flow rate

The minimum flow rate through the boiler is obtained from the following formula:

$$\frac{\text{nominal heat output (kW)}}{70} = \text{m}^3/\text{h}$$

This minimum flow must be maintained for 5 minutes after the burner stops firing to avoid high temperature shut - down due to residual heat gain.  
Due to the design and manufacture of the boiler no specific minimum water flow requirement exists other than for over-temperature protection.

#### 5.1.4 Water treatment

Under normal conditions water treatment is not required (see our leaflet on water quality recommendations).

### 5.2 Economisers

ECO's can be delivered upon request (for natural gas only).

### 5.3 Flue gas discharge

For the discharge of the flue gases, chimney draught is not required.  
Tests have shown that very good combustion results are obtained with zero draught at the boiler outlet.

### 5.4 Noise production

The noise level taken at a distance of 1 m around the boiler is approximately 70 to 85 dBA. The noise level at the chimney outlet will, depending on load, type of burner and chimney situation, vary from 70 to 90 dBA, taken at a distance of 1 m from the outlet. If this noise production give rise to problems in the immediate vicinity, then noise reducing or absorbing measures should be taken.

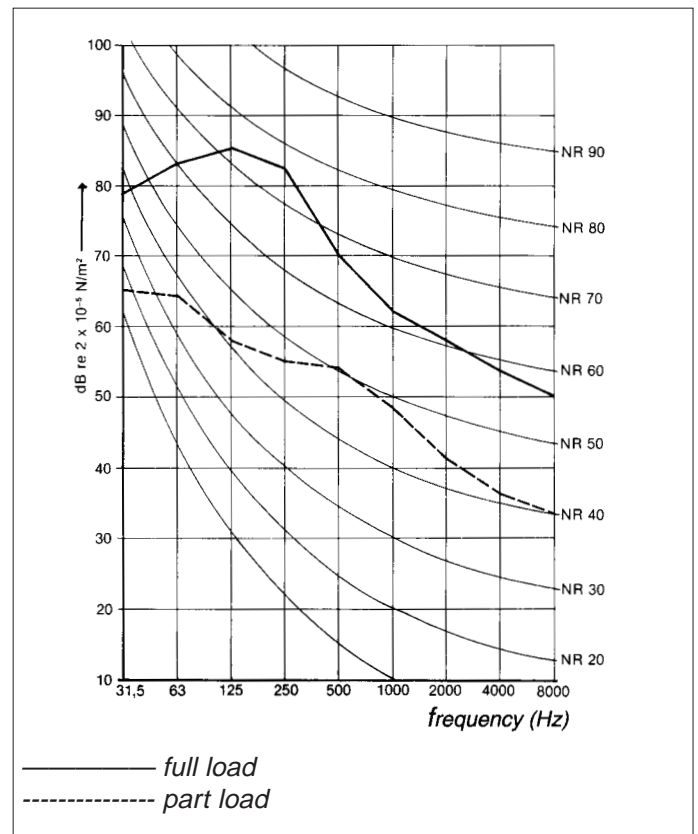

Fig. 03 Noise level readings without burner silencer

The values that have been taken are averages obtained from various measurements carried out at a distance of approximately 1 m around the boiler and at a height of approximately 1 m.

## 6. INSTALLATION REQUIREMENTS

### 6.1 Installation recommendations in the boiler house

The necessary minimum installation space of the boiler can be seen from figure 04.

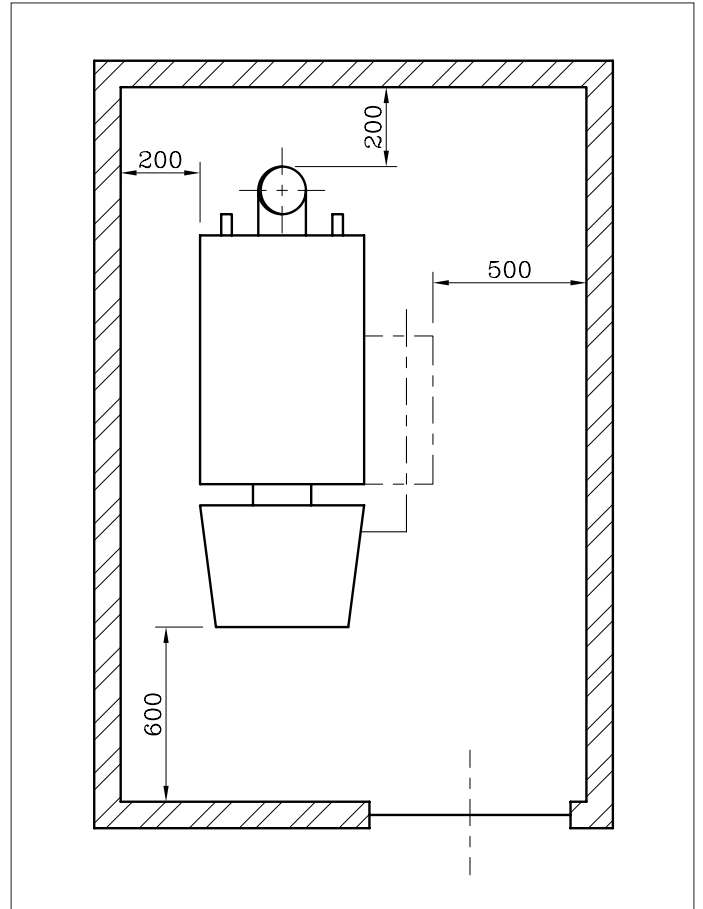

Fig. 04 Installation recommendations in the boiler house

## 7. ASSEMBLY GUIDELINES AND INSTALLATION REQUIREMENTS

### 7.1 General

The Remeha boilers P 200 - 4 to 7 sections can be delivered in individual parts or assembled. The Remeha boilers P 200 - 8 to 12 sections are delivered in individual parts.

### 7.2 Water connections

The water connections are at the rear of the boiler.  
The flow and return connections consist of threaded male connections :

- 4 - 7 sections 1 1/2" BSP
- 8 - 12 sections 2" BSP

Flange connections in accordance with DIN 2633 can be delivered on request (Ø 70 mm ID).

The top flange at the front of the boiler is provided with 3 x R 1/2" threaded holes for the fitting of the thermostat pockets. The return connection is provided with a R 3/4" threaded hole in which a drain off cock is fitted.

### 7.3 Delivery in individual parts

#### 7.3.1 General

The sizes of the boiler parts are such that they all can enter the boiler house through a normal entrance. The casing and equipment parts are delivered in packaged units. If necessary, the boiler can be put into operation without casing. The casing can be added at a later stage without dismantling the water connections. On request the boiler can be delivered with adjustable boiler feet.

#### 7.3.2 Boiler assembly

Assembly and installation of a boiler delivered in individual parts should only be undertaken by a recognized and approved engineer and in accordance with the assembly manual. Local regulations laid down by the relevant authorities must be adhered to.

### 7.4 Delivery assembled (4 to 7 sections only)

The boiler is delivered completely assembled in a crate and on a pallet. Just the casings and the instrument panel are delivered separate in package units in the crate. The boiler is delivered with adjustable boiler feet (figure 05). By unscrewing the boiler feet, the boiler lifts itself up from the pallet. The pallet can now be dismantled and taken away (figure 06). Now the boiler level can be adjusted horizontal and at the right height (figure 07).

After the installation of the boiler, the casings and the instrument panel can be fitted (figure 08).

If necessary, the boiler can be put into operation without casing. The casing can be added at a later stage without disconnecting the water connections.

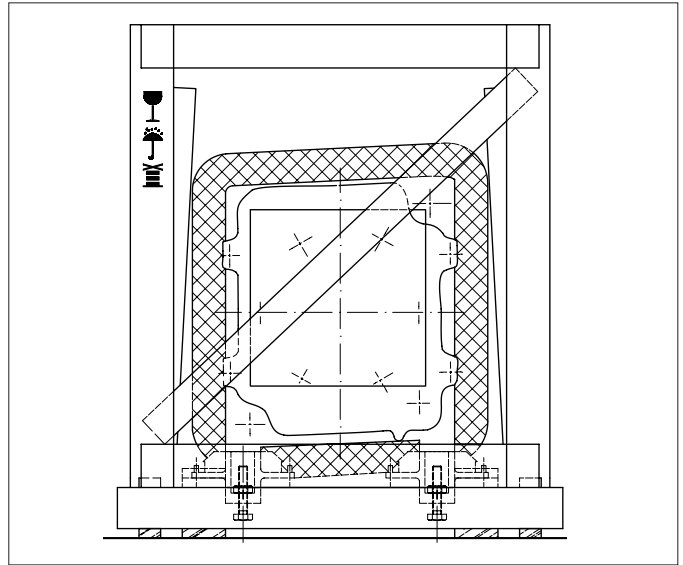

Fig. 05 The boiler completely assembled in a crate and on a pallet.

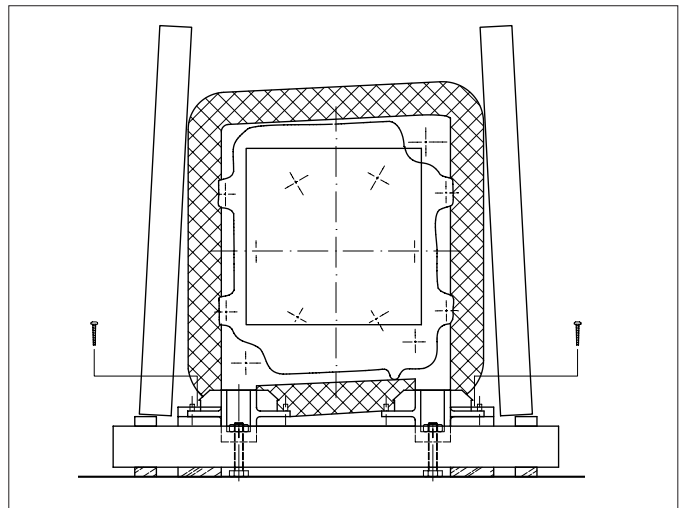

Fig. 06 The pallet dismantled and taken away

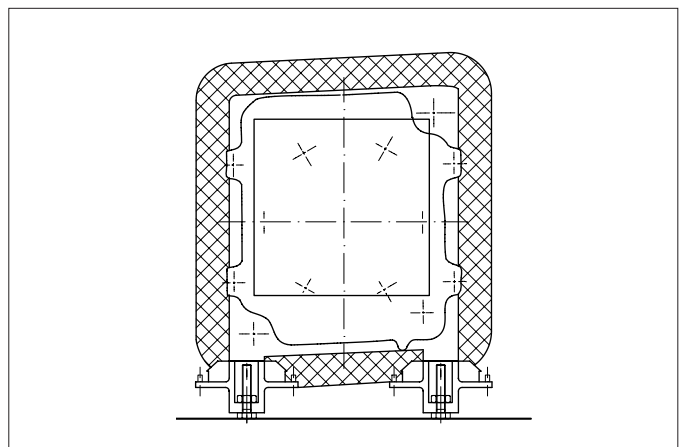

Fig. 07 The boiler adjusted horizontal and at the right height



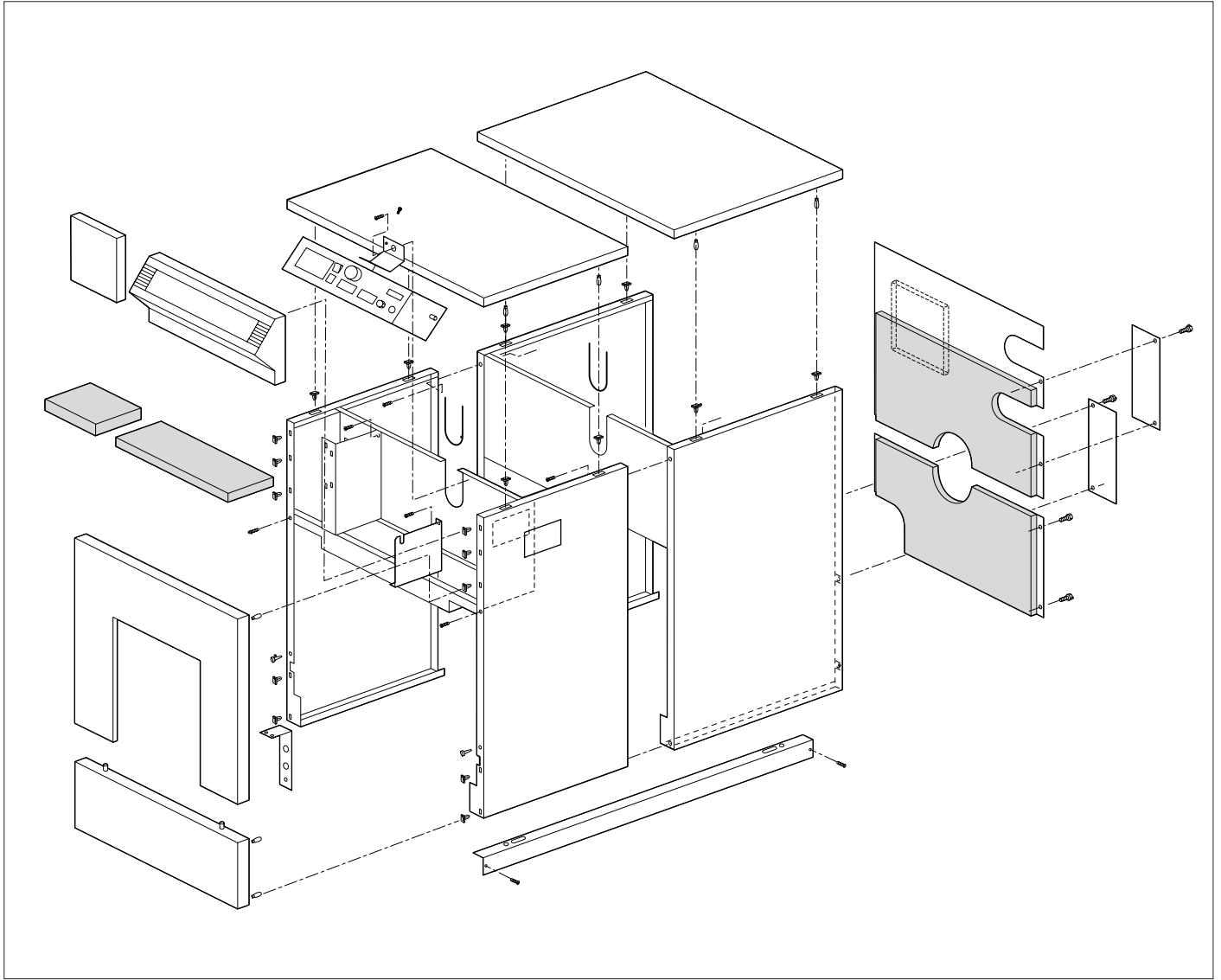

Fig. 08 Mounting casings and the instrument panel

## 8. INSTRUMENT PANELS

### 8.1 Equipment contents

The panels contain all the necessary control and measuring instruments required to control the boiler. The connections have to be made on a terminal strip. The capillaries and sensor wires, which come from the control panel, are placed in the instrument pockets that are fitted at the front of the boiler.

See par. 8.2 for a instrument panel On/Off and par. 8.3 for a instrument panel High/Low with hour run meters. Several extra options can be built into the panels. Ask our technical department.

### 8.2 Instrument panel On/Off

#### 8.2.1 Lay out instrument panel On/Off

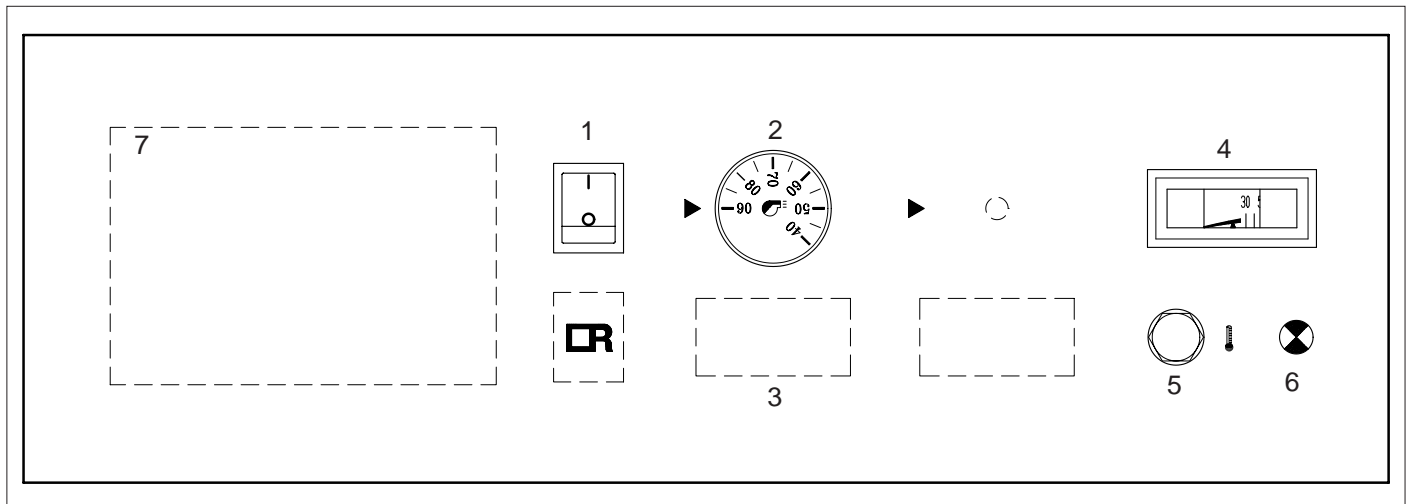
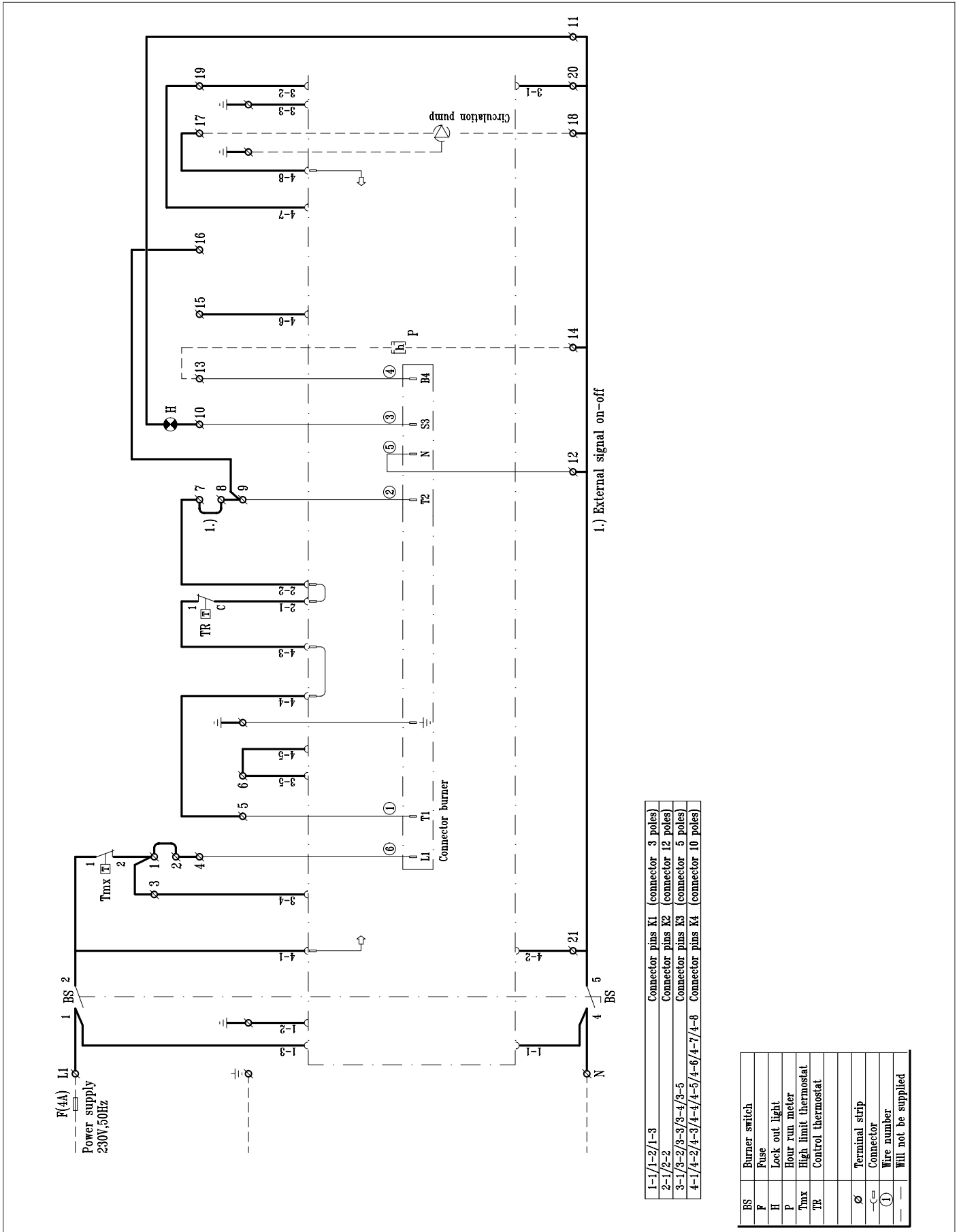

Fig. 09 Layout of the instrument panel On/Off

1. Operating switch (On/Off),
2. Control thermostat  
Setting between 35°C - 95°C,
3. Option for hour run meter,
4. Analogue thermometer water temperatur,
5. High limit thermostat 110°C (lock out),
6. Central warning light,
7. Option for **rematic**® weather compensator.

### 8.2.2 Wiring diagram instrument panel On/Off



- 1-1/1-2/1-3 Connector plus K1 (connector 3 poles)
- 2-1/2-2 Connector plus K2 (connector 12 poles)
- 3-1/3-2/3-3/3-4/3-5 Connector plus K3 (connector 5 poles)
- 4-1/4-2/4-3/4-4/4-5/4-6/4-7/4-8 Connector plus K4 (connector 10 poles)

BS	Burner switch
F	Fuse
H	Lock out light
P	Hour run meter
Tmx	High limit thermostat
TR	Control thermostat
∅	Terminal strip
-c=	Connector
(1)	Wire number
---	Will not be supplied

Fig. 10 Wiring diagram instrument panel On/Off

## 8.3 Instrument panel High/Low

### 8.3.1 Lay out instrument panel High/Low with hour run meters

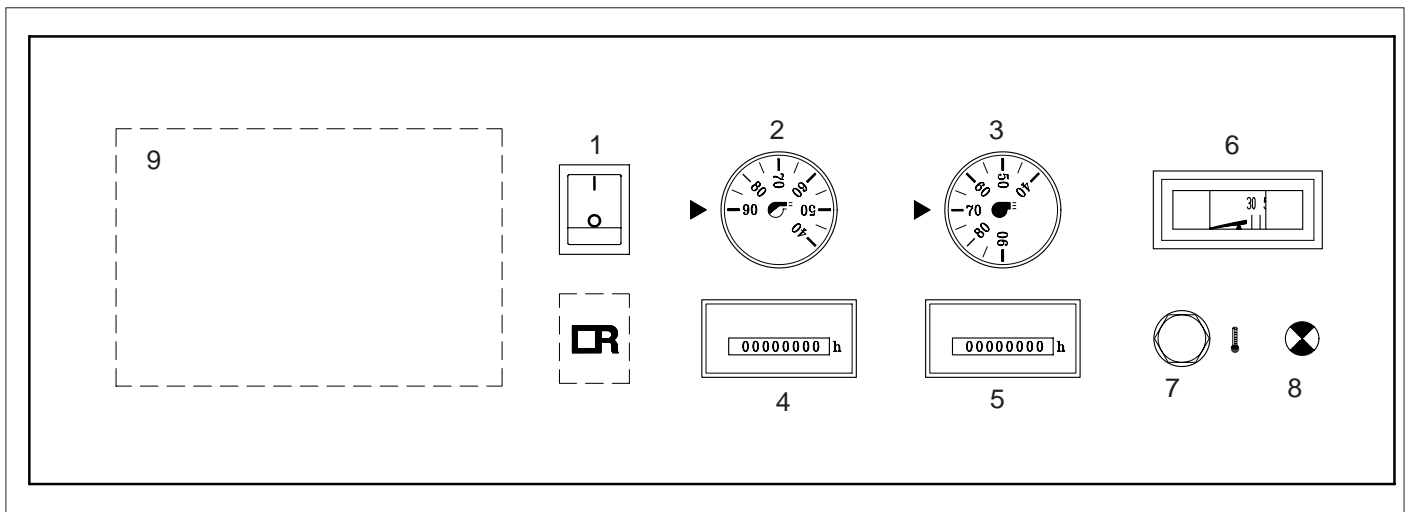

Fig. 11 Layout of the instrument panel High/Low with hour run meters

1. Operating switch (On/Off)
2. Control thermostat  
Setting between 35°C - 95°C
3. High/Low thermostat  
Setting between 35°C - 95°C
4. Hour run meter total running hours (option)
5. Hour run meter full load running hours (option)
6. Analogue thermometer water temperature
7. High limit thermostat 110°C (lock out)
8. Central warning light
9. Option for **rematic**<sup>®</sup> weather compensator

### 8.3.2 Wiring diagram instrument panel High/Low

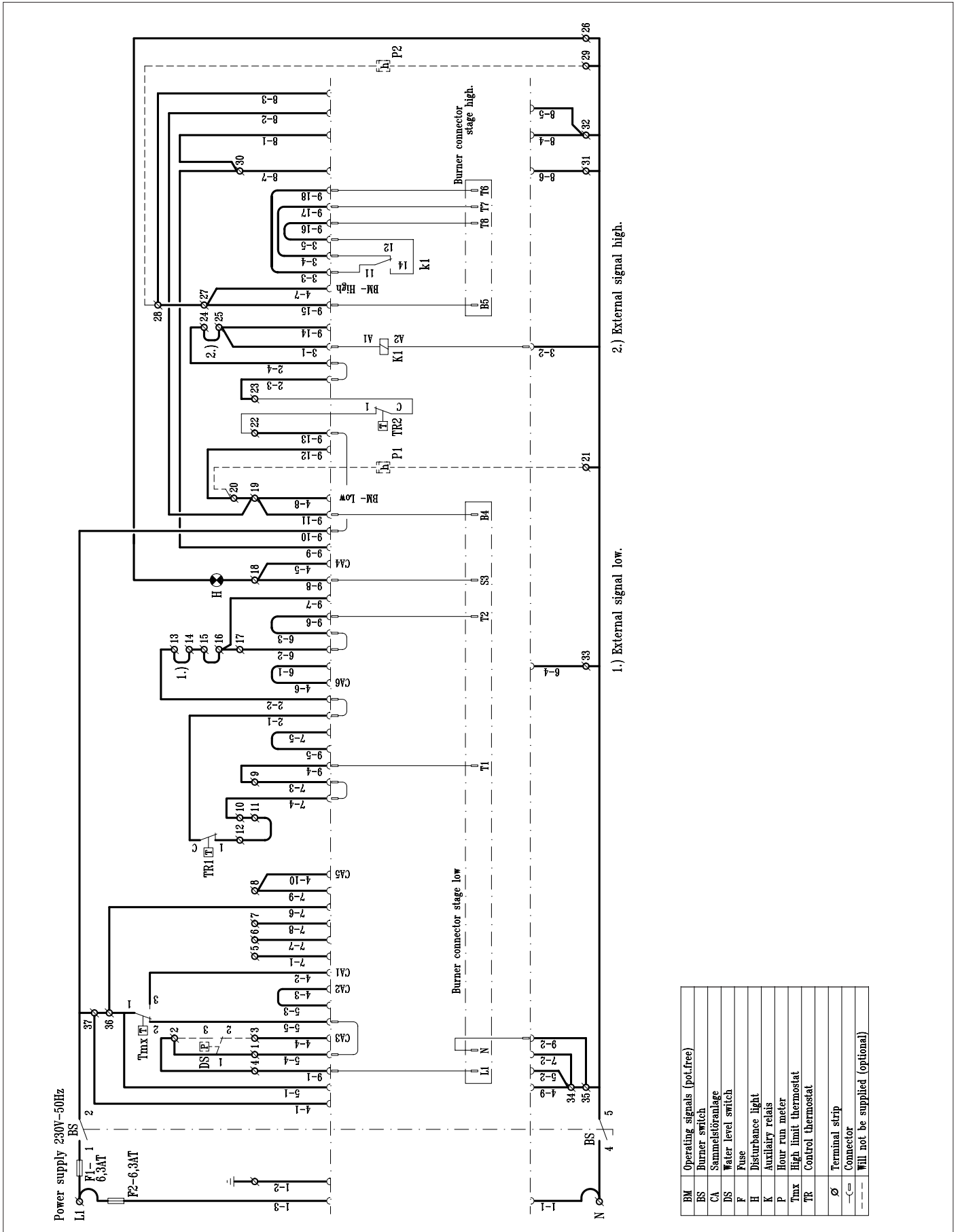

Fig. 12 Wiring diagram instrument panel High/Low

## 9. COMMISSIONING

### 9.1 Pressurized boiler with gas burner

#### 9.1.1 Commissioning procedure

If the boiler is to be put into operation again following a period of non-use, then the following procedure must be carried out :

- a. Open the main gas cock.
- b. Switch the weather-compensator (if fitted) over to manual operation.
- c. Turn the thermostats to their highest setting.
- d. Switch on the circulation pump.
- e. Switch on the main switch.
- f. Switch on the operation switch in the instrument panel.
- g. Consult burner manufacturer commissioning details.

#### Warning

If the instrument panel is fitted with a weather compensator, set the programm switch to 'manual' position. The following will now take place: the gas burner fan will start running so that during the purging time the combustion chamber will be ventilated with the air damper fully opened. The air damper will then go into start position. Ignition flame lights up and is checked. Then the control box gives the all clear signal for the burner to switch over to full load.

#### 9.1.2 Putting out of operation

It is sufficient to switch off the operation switch on the instrument panel. It is recommended that in the event of work being carried out on the burner, the main gas cock is shut.

### 9.2 Pressurized boiler with oil burner

#### 9.2.1 Commissioning procedure

If the boiler is to be put into operation again following a period of non-use, then the following procedure must be carried out :

- a. Open the main oil cock.
- b. Switch the weather-compensator (if fitted) over to manual operation.
- c. Turn the thermostat to their highest setting.
- d. Switch on the circulation pump.
- e. Switch on the main switch.
- f. Switch on the operation switch in the instrument panel.
- g. Consult burner manufacturer commissioning details.

#### Warning

If the instrument panel is fitted with a weather compensator, set the programm switch to 'manual' position. The following will now take place: the oil burner fan will start running so that during the purging time the combustion chamber will be ventilated with the air damper fully opened. The air damper will then go into start position. Ignition flame lights up and is checked. Then the control box gives the all clear signal for the burner to switch over to full load.

#### 9.2.2 Putting out of operation

It is sufficient to switch off the operation switch on the instrument panel. It is recommended that in the event of work being carried out on the burner, the main oil valve is shut.

## 10. FAULT FINDING

### 10.1 High Limit thermostat lockout

- Check the water circulation (circulation pump). Reset the High Limit thermostat (Reset button is on the instrument panel under the cover cap of the High Limit thermostat).
- Advise the installer in the event of continued lock outs.

## 11. MAINTENANCE RECOMMENDATIONS

### 11.1 General

Depending on the operational conditions, the block and the burner must be checked and cleaned one or more times a year.

### 11.2 Maintenance instructions

- Cleaning of the boiler
  - Put boiler out of operation.
  - Open the front door, if necessary after dismantling the burner.
  - Remove the retarders (only for the 4 - 9 sections).
  - Clean the combustion chamber and flue passes using a suitable brush.
  - Clean the removed retarders (4 - 9 sections).
  - Remove the rear panel of the boiler and remove the cleaning cover (underneath the smoke box).
- Vacuum clean the boiler and the combustion gas chamber.
- Renew the front door seals after cleaning the boiler.
- Re-assemble the removed parts and close the front door.
- Re-assemble the burner (if dismantled).
- Check the boiler combustion side for leakage.
- Check the equipment for proper functioning and if necessary re-adjust the control and safety equipment.
- Carry out combustion analysis.
- Check the water connections.



**NL**  
**Remeha B.V.** Tel. 055-5496969  
Kanaal Zuid 110 Fax 055-5496496  
NL - 7332 BD Apeldoorn 055-5496287  
Email: remeha@remeha.com

**GB**  
**Broag Ltd.** Tel. 0118-9783434  
Molly Millars Lane Telex 849137  
GB - Wokingham, Berks. Fax 0118-9786977  
RG 41 2PY Email:  
Boilers@broag.ltd.uk

**F**  
**REMEHA FRANCE S.A.**  
Bâtiment 38 Tél. 04 42 245 970  
Parc Club du Golf-Les Milles Fax 04 42 245 979  
F - 13856 Aix-en-Provence Cedex 3

**CH**  
**Cipag S.A.**  
Zone Industrielle Tél. 021 9266666  
Le Verney Télex 451158  
CH - 1604 Puidoux-Gare Fax 021 9462521

**D**  
**Remeha Wärmetechnik GmbH.**  
Bischofstrasse 96 Tel. 02151 5587-0  
D-47809 Krefeld-Oppum Fax 02151 542445

**Département Services**  
URBAPARC  
Bâtiment G 3  
6 / 8 Bd. de la Libération Tél. 01 48 131 190  
F - 93284 St. Denis Cedex Fax 01 48 130 673

**GR**  
**Technotherm S.A.**  
35, Grigoriou Lampraki str. Tel. 031 948-972  
GR - 546 38 Thessaloniki Fax 031 943-207

**S**  
**Abac VVVS International AB**  
Morbyleden 22  
S-18232 Danderyd Tel. 08-7534230  
Fax 08-7534236

**B**  
**J.L. Mampaey b.v.b.a.**  
Uitbreidingstraat 54 Tel. (03) 2307106  
B - 2600 Berchem - Télex 33601  
Antwerpen Fax (03) 2301153

**Palver S.A.**  
60, Antoganis str. Tel. 5243841  
GR - 104 42 Athens Fax 5134256

**H**  
**Marketbau Remeha KFT**  
H - 1138 Budapest, Tel. 173 2993  
Népfürdő u.19/e Fax 173 2591

**Thema S.A.**  
Av. Emile Digneffe 19 Tel. (04) 2529868  
B - 4000 Liège Fax.(04) 2520967

**BIH**  
**Brugman BH d.o.o.**  
Trg Haroja 10 Tel./Fax (0) 71 646 188  
BIH - 71000 Sarajevo

**L**  
**Ultracalor Nouvelle S.A.**  
Z.I. Bredewues Tel. 0352 348251  
L - 1259 Senningerberg Telex 2706  
B.P. 96 Fax 0352 348255  
L - 6905 Niederranven

**E**  
**Termibarna S.A.**  
Zamora 55-59 Tel. 03 3000204  
E - 08005 Barcelona Fax 03 3009558

**AUS**  
**Tomlinson Boilers**  
2-4 Beaufort Street Preston  
Northland Centre Tel. 00 / 61364168554  
AUS - Victoria 3072 Fax 00 / 61364168558

**PL**  
**Brugman**  
**Polska Sp. Z o.o.** Tel. 071-73 79 54  
ul. Minska 54-56 Tel. 071-73 79 73  
PL - 54-610 Wroclaw Fax. 071-73 79 68

**Cuatrocesa S.A**  
Marqués de Monteagudo,  
22, Bajo B Tel. (01)345 96 07  
E - 28028 Madrid Fax (01)345 63 26

**DK**  
**Vaillant A/S**  
Drejergangen 3a Tel. 46 160 200  
DK - 2690 Karlslunde Fax 46 160 200

**R**  
**D.D. Promotherm SRL**  
Str. Splaiul Independetei 7 Tel. 40 1 335 7977  
Bl. 101 Izvor Sc 3, ET. 1 Fax.40 1 335 0134  
AP. 40, Sector 5 70501 Bucuresti

**D.A.C. S.A.**  
Poligono Cogullada  
Tomás A. Edison, 29  
E - 50014 Zaragoza Tel. (076) 396558

**TR**  
**Emas Makina Sanayi A.S.**  
Organize Sanayi Bölgesi Tel. 216 414 9654  
Sanayi Cad. No: 15 Fax 216 348 8635  
TR - 81520 Seyhli - Pendik/ISTANBUL

**CZ**  
**APS-PRAHA s r.o.** Tel. 02/663 113 51  
Sokolovská 270 02/824818  
CR - 190 00 Praha 9 Fax 02/6841744

**Norte Comercial Organización S.A.**  
Carretera Asua-Erletxes no. 2  
Barrio Sangróniz Tel. (94) 471 03 33  
E-48016 LOIU (Vizcaya) Fax (94) 471 11 52

**A**  
**Heizbösch K.G.**  
Grüttstrasse 11 Tel. 5577-8131-0  
A - 6890 Lustenau Fax 5577-8131250

**SL**  
**Tess Spol s r.o.**  
Nam SV Anny 3 Tel. 0831 527353  
911 47 Trencin Fax 0831 525057  
Slovakia

Our policy is continuous development.  
We reserve the right to alter specifications  
without prior notification.